

12SPX80 12V80Ah



SPECIFICATION

• NOMINAL VOLTAGE	: 12 V
• NOMINAL CAPACITY(20 hr)	: 80 Ah
• DIMENSIONS	
TOTAL HEIGHT	: 213 mm
CONTAINER HEIGHT	: 209 mm
LENGTH	: 259 mm
WIDTH	: 168 mm
• WEIGHT	: APPROX 27Kg
• CONTAINER MATERIAL	: UL94V-0 ABS
• INTERNAL RESISTANCE(25°C , 77 °F)	: ~5.8 mΩ
• DISCHARGE CAPACITY UNDER DIFFERENT TEMPERATURES	
40°C	: ~102%
25°C	: ~100%
0 °C	: ~85%



Cycle numbers VS Depth of discharge (D.O.D)

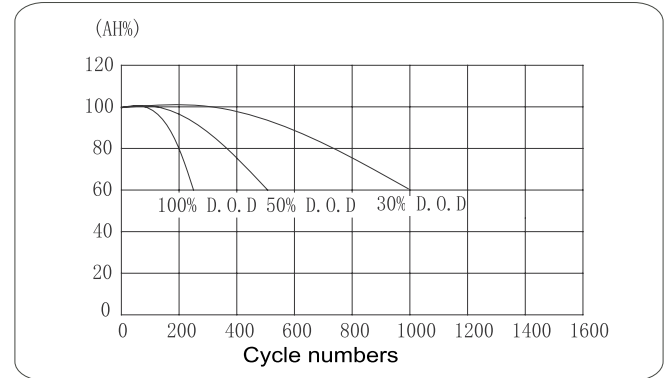

DISCHARGE CHARACTERISTICS 25°C (77°F)

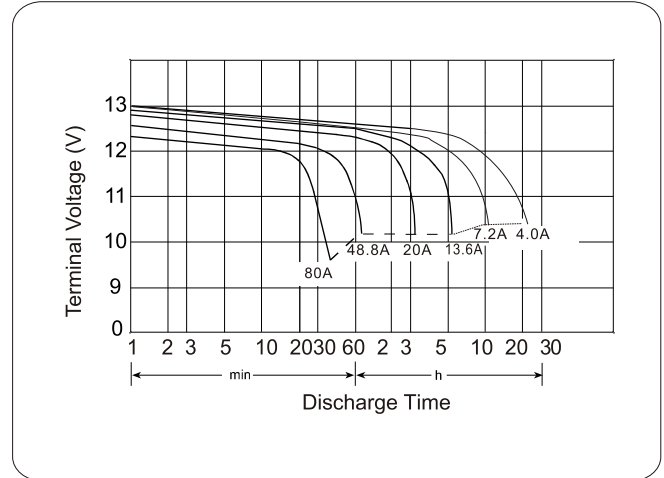

DIMENSIONS

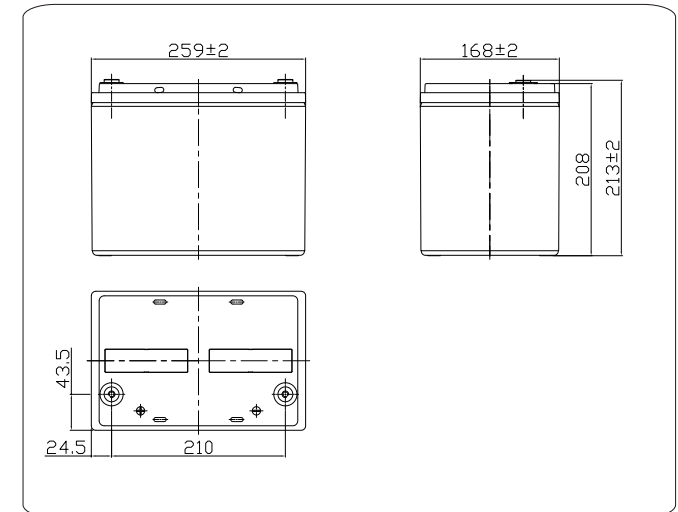

CHARACTERISTICS

• CAPACITY 25°C / 77 °F	
20 hr @ 4.0 A	: 80.0 Ah
5 hr @ 13.6 A	: 68.0 Ah
1 hr @ 48.8 A	: 48.8 Ah
1 C @ 80 A	: 40.0 Ah
• CHARGING VOLTAGE (25°C , 77 °F)	
STANDBY USE	: 13.65V±0.15 V
CYCLE USE	: 14.7V ±0.3 V
• MAX DISCHARGE CURRENT	: 240 A (5 sec)
• MAX CHARGING CURRENT	: 20 A
• SELF-DISCHARGE RESIDUAL CAPACITY(25°C , 77 °F)	
AFTER 3 MONTHS	: ~90%
AFTER 6 MONTHS	: ~82%
AFTER 12 MONTHS	: ~70%

TERMINAL

