

## SPECIFICATION

• NOMINAL VOLTAGE	: 12 V
• NOMINAL CAPACITY(20 hr)	: 150.0 Ah
• DIMENSIONS	
TOTAL HEIGHT	: 220 mm
CONTAINER HEIGHT	: 220 mm
LENGTH	: 483 mm
WIDTH	: 170 mm
• WEIGHT	: APPROX 46 Kg
• CONTAINER MATERIAL	: UL94HB ABS
	: UL94V-0 ABS
• INTERNAL RESISTANCE( 25°C , 7.7 °F )	: ~2.84mΩ
• DISCHARGE CAPACITY UNDER DIFFERENT TEMPERATURES	
40°C	: ~102%
25°C	: ~100%
0 °C	: ~85%



## CHARACTERISTICS

• CAPACITY 25°C / 77 °F	
20 hr @ 7.5 A	:150.0 Ah
5 hr @ 25.5 A	: 127.5 Ah
1 hr @ 91.5 A	: 91.5 Ah
1 C @ 150 A	: 75.0 Ah
• CHARGING VOLTAGE ( 25°C , 77 °F )	
STANDBY USE	: 13.62V/bloc
FREQUENT DISCHARGE USE	: 14.1-14.4 V/bloc
• MAX CHARGING CURRENT	: 37.5 A
• SELF-DISCHARGE RESIDUAL CAPACITY( 25°C , 77 °F )	
AFTER 3 MONTHS	: ~90%
AFTER 6 MONTHS	: ~82%
AFTER 12 MONTHS	: ~70%

## Cycle numbers VS Depth of discharge (D.O.D)

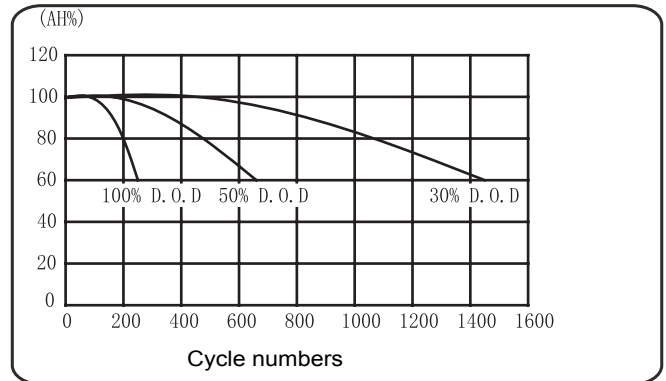

## DISCHARGE CHARACTERISTICS 25°C (77°F)

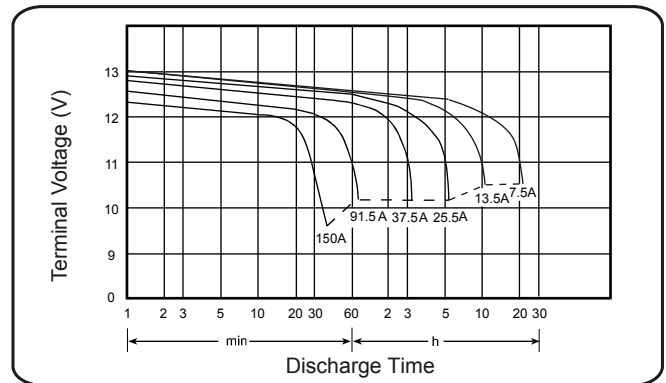

## DIMENSIONS

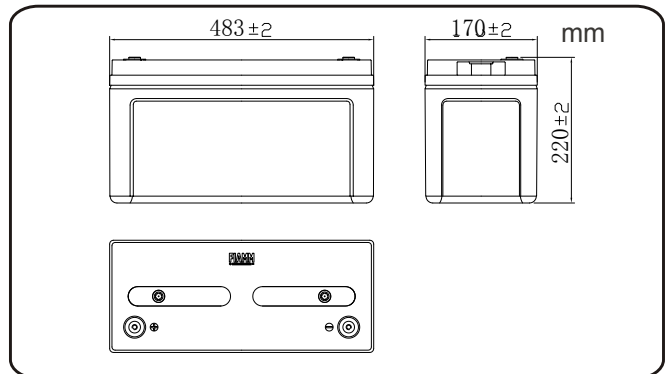

## TERMINAL

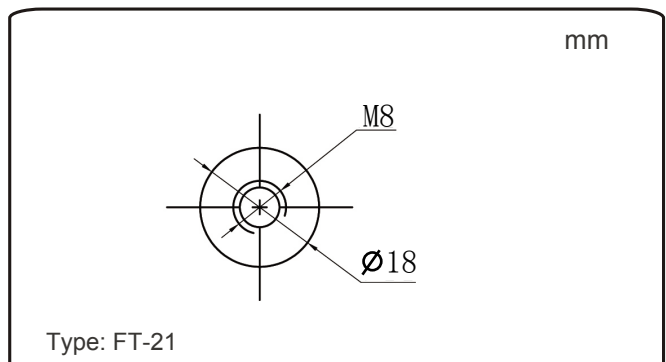

Note: Specifications are subject to change without further notice.