

SPECIFICATION

● NOMINAL VOLTAGE	: 12 V
● NOMINAL CAPACITY(20 hr)	: 65.0 Ah
● DIMENSIONS	
TOTAL HEIGHT	: 195 mm
CONTAINER HEIGHT	: 191 mm
LENGTH	: 272 mm
WIDTH	: 166 mm
● WEIGHT	: APPROX 23.2Kg
● CONTAINER MATERIAL	: UL94HB ABS
	: UL94V-0 ABS
● INTERNAL RESISTANCE(25°C , 77 °F)	: ~6.5 mΩ
● DISCHARGE CAPACITY UNDER DIFFERENT TEMPERATURES	
40°C	: ~102%
25°C	: ~100%
0 °C	: ~85%

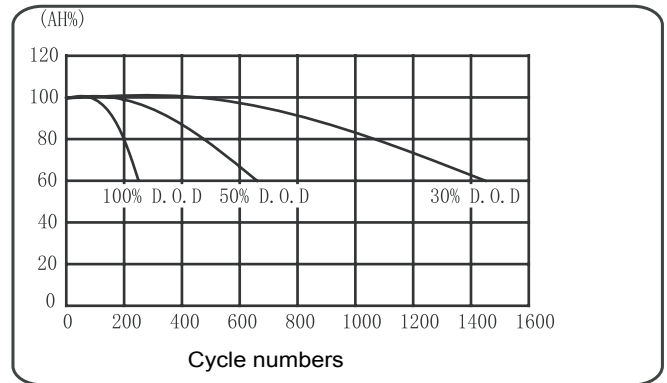

Cycle numbers VS Depth of discharge (D.O.D)



DISCHARGE CHARACTERISTICS 25°C (77°F)

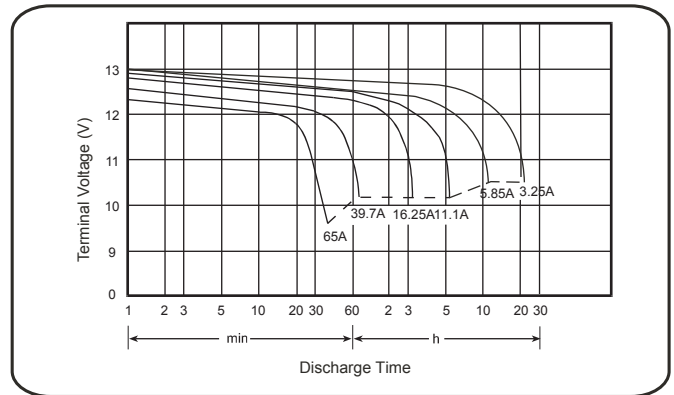

DIMENSIONS

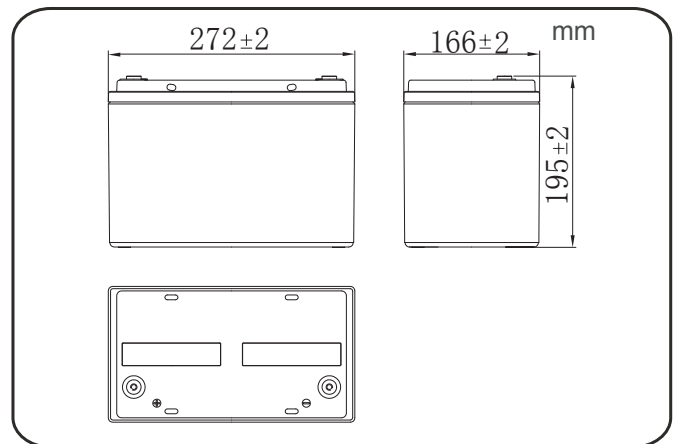

CHARACTERISTICS

● CAPACITY 25°C / 77 °F	
20 hr @ 3.25A	: 65.0 Ah
5 hr @ 11.1 A	: 55.3 Ah
1 hr @ 39.7 A	: 39.7 Ah
1 C @ 65 A	: 32.5 Ah
● CHARGING VOLTAGE (25°C , 77 °F)	
STANDBY USE	: 13.62V/bloc
FREQUENT DISCHARGE USE	: 14.1-14.4 V/bloc
● MAX CHARGING CURRENT	: 16.25 A
● SELF-DISCHARGE RESIDUAL CAPACITY(25°C , 77 °F)	
AFTER 3 MONTHS	: ~90%
AFTER 6 MONTHS	: ~82%
AFTER 12 MONTHS	: ~70%

TERMINAL

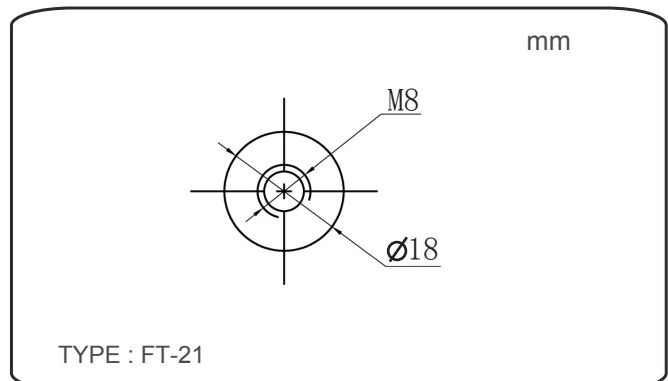

Note: Specifications are subject to change without further notice.